



HX8808E

High Efficiency, 3A, Multi-Cells Li-Ion Battery Charger

Parameters Subject to Change Without Notice

DESCRIPTION

The HX8808E is a buck boost converter targets HVDC fast charging system.

The HX8808E supports 1 to 4 cells Li-ion battery, the full charge voltage and charge current can be programmed through external resistor.

The HX8808E implements the Buck Boost converter with an H-bridge. The integrated low $R_{DS(on)}$ MOSFET minimizes physical footprint, maximizes charge efficiency. Built-in loop compensation simplifies the circuit and design. PFM is engaged to maintain high efficiency at light load current.

HX8808E guarantees robustness with thermal protection and battery under voltage lockout.

FEATURES

- Integrate low $R_{DS(on)}$ power MOSFET
- Wide input range: 4.2V-21.0V, support 1 to 4 cells battery charge
- Full charge voltage: 1.2V-17V through external resistor or selectable by BATFB pin
- High efficiency buck-boost transition
- 450kHz Switching frequency
- Programmable charge current, up to 3A
- Quiescent current: <5uA
- Integrate battery short protection
- Integrate thermal protection
- QFN3*4 package

APPLICATIONS

- Power bank systems
- Battery and supercapacitor charging
- USB power delivery
- Industrial applications
- Automotive systems

TYPICAL APPLICATION

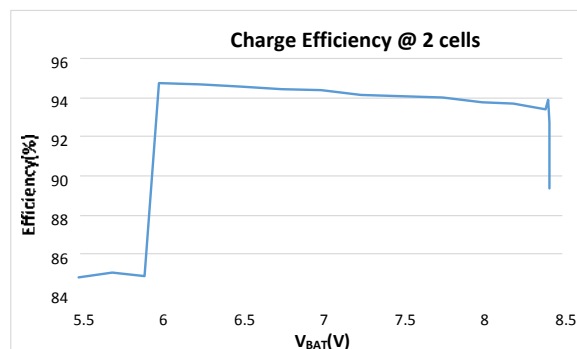
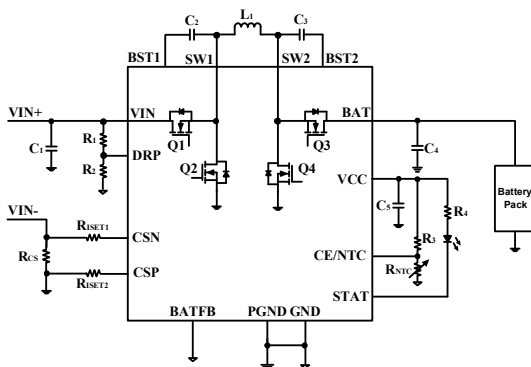



ORDER INFORMATION

DEVICE ¹⁾	PACKAGE	TOP MARKING ²⁾
HX8808E	DFN3X4-15	EEOEE XXXX

Notes:

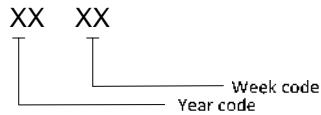

PIN CONFIGURATION

TOP VIEW

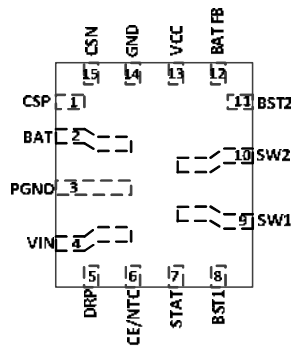

ABSOLUTE MAXIMUM RATING¹⁾

VIN, BAT, SW1, SW2 Pin	-0.3V to 24V
BST1-SW1, BST2-SW2	-0.3V to 6.5V
All Other Pins	-0.3V to 6.5V
Junction Temperature ²⁾³⁾	150°C
Lead Temperature	260°C
Storage Temperature	-65°C to +150°C
ESD Susceptibility (Human Body Model)	2kV



RECOMMENDED OPERATING CONDITIONS

Input Voltage VIN	4.2V to 21V
Battery Voltage VBAT	3.0V to 17V
Operation Junction Temp (T _J)	-40°C to +125°C

THERMAL PERFORMANCE⁴⁾

θ_{JA} θ_{JC}

QFN3X4-15.....	48.....11°C/W
----------------	---------------

Note:

- 1) Exceeding these ratings may damage the device.
- 2) The HX8808E guarantees robust performance from -40°C to 150°C junction temperature. The junction temperature range specification is assured by design, characterization and correlation with statistical process controls.
- 3) The HX8808E includes thermal protection that is intended to protect the device in overload conditions. Thermal protection is active when junction temperature exceeds the maximum operating junction temperature. Continuous operation over the specified absolute maximum operating junction temperature may damage the device.
- 4) Measured on JESD51-7, 4-layer PCB.



ELECTRICAL CHARACTERISTICS

<i>V_{IN}=5V, T_A=25 °C, unless otherwise stated</i>						
Item	Symbol	Condition	Min.	Typ.	Max.	Units
Power supply						
V _{BAT} voltage range	V _{BAT}		3.0		21	V
V _{CC} output voltage	V _{CC}		4.7	5.0	5.3	V
V _{CC} output current limit	I _{VCC}	V _{CC} >2.7V		50		mA
Supply current in shut-down mode	I _Q	V _{BAT} =8V, CE=0V		3	5	μA
Controller						
Switch frequency	F _{sw} ⁵⁾		350	450	450	kHz
Switch minimum off time	T _{off_min} ⁵⁾		80	100	120	ns
Charge enable Threshold	V _{CE}		14.7%	16.7%	18.7%	V _{CC}
Bucktop switch on-resistance	R _{dsbkTG} ⁵⁾			20	28	mΩ
Buck bottom switch on-resistance	R _{dsbkBG} ⁵⁾			20	28	mΩ
Boost top switch on-resistance	R _{dsbstTG} ⁵⁾			20	28	mΩ
Boost bottom switch on-resistance	R _{dsbstBG} ⁵⁾			20	28	mΩ
Charge						
Floating BAT Voltage	V _{CV}	V _{BATFB} = GND	8.358	8.4	8.442	V
		Set by divider resistor	3.0	-	17	
BAT feedback voltage	V _{BATFB}	External resistor divider	1.191	1.2	1.212	V
BAT Recharge threshold	V _{REC}	V _{BATFB} = GND	8.118	8.2	8.282	V
BAT recharge feedback threshold	V _{RECFB}	External resistor divider	1.159	1.171	1.183	V
CC mode charge current	I _{CC}	R _{CS} =10mΩ, R _{ISET1} =2K R _{ISET2} =1.5K	1.9	2	2.1	A
Charge termination current	I _{TER}	R _{CS} =10mΩ, R _{ISET1} =2K R _{ISET2} =1.5K		10%		I _{CC}
Battery full charge deglitch time	T _{FULL}	I _{CC} < I _{TER}		500		ms
Trickle mode charge current	I _{TRI}		10%	20%	30%	I _{CC}
Trickle mode battery threshold	V _{TRI}	V _{BATFB} = GND	5.9	6.0	6.1	V
Trickle mode feedback threshold	V _{TRIFB}			0.857		V
Trickle charge time-out duration	T _{TRI}			55		min
VIN UVP threshold	V _{IN_UVP}	VIN rising	4.0	4.2	4.3	V
		VIN falling	3.8	4.0	4.1	V
VIN delay to start charging	T _{chg_delay}			150		ms
DRP reference voltage for adaptive current limit	V _{DRP}		0.885	0.9	0.915	V
Protection						



Battery under temperature protection threshold	V_{UTP}		70.2%	72.2%	74.2%	V_{CC}
Battery over temperature protection threshold	V_{OTP}		27.2%	29.2%	31.2%	V_{CC}
Thermal shutdown threshold ⁵⁾	$T_{SHUT}^{5)}$			150		°C
Thermal recovery threshold ⁵⁾	$T_{REC}^{5)}$			130		°C

Notes:

5) Guaranteed by design.



PIN DESCRIPTION

Pin No.	Name	Description
1	CSP	Positive terminal of battery charge current sense.
2	BAT	Battery positive terminal.
3	PGND	Power Ground.
4	VIN	Main supply pin, connect to adaptor.
5	DRP	VIN droop allowance program pin.
6	CE/NTC	This is a multi-purpose pin. 1. Charge enable pin. 2. Battery temperature protection pin.
7	STAT	Open-drain charge status output. Connect the STAT pin to a logic rail via 10kΩ resistor. The STAT pin indicates charger status. Connect a current limit resistor and a LED from VCC to this pin. Charge in progress: LOW Charge complete or charger in SLEEP mode: HIGH Charge suspend (fault response): 1-Hz, 50% duty cycle pulses.
8	BST1	VIN side bootstrap supply pin for top switch. 0.1uF capacitor is connected between BST1 and SW1 pins.
9	SW1	VIN side power switching node. connect to SW2 with inductor
10	SW2	BAT side power switching node.
11	BST2	BAT side bootstrap supply pin for top switch. 0.1uF capacitor is connected between BST2 and SW2 pins.
12	BATFB	Battery float voltage configuration pin. 1. This pin tied to GND, sets 2 cells float voltage. Pin short to GND: 8.4V. 2. And the float voltage could be set to any value (3.0V-17V) by the external divider resistor.
13	VCC	5V LDO for power driver and internal circuit. Must be bypassed to GND with a minimum of 10uF ceramic capacitor for stable operation.
14	GND	Signal GND.
15	CSN	Negative terminal of battery charge current sense.



TYPICAL PERFORMANCE CHARACTERISTICS

$V_{IN} = 5V$, $L = 3.3\mu H$, $C_{IN} = 20\mu F$, $C_{OUT} = 20\mu F$, $T_A = +25^\circ C$, unless otherwise noted

Tricklecharge @ 1 cell

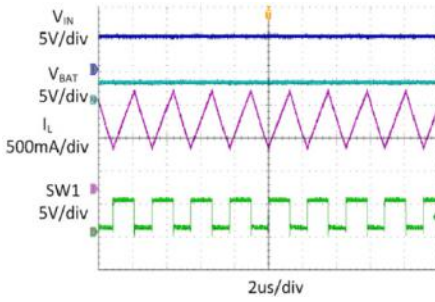

Constantcurrentcharge@ 1 cell

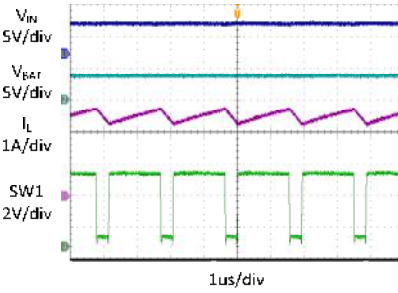

Constantvoltagecharge@ 1 cell

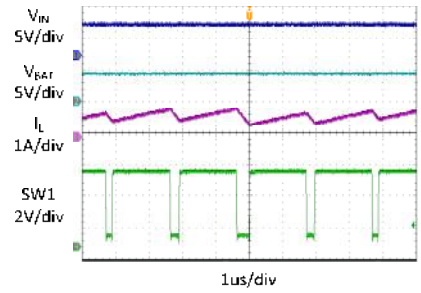

Tricklecharge @ 2 cells

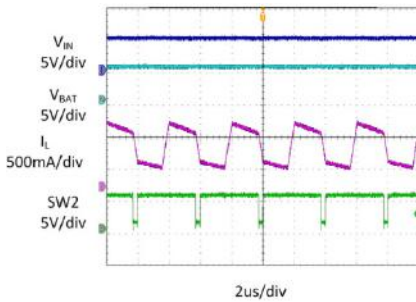

Constantcurrentcharge@ 2 cells

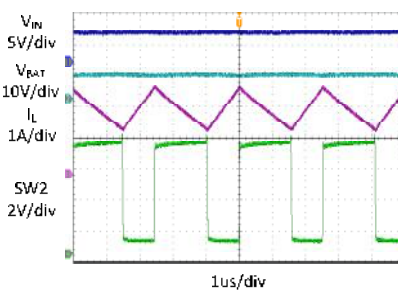

Constantvoltagecharge@ 2 cells

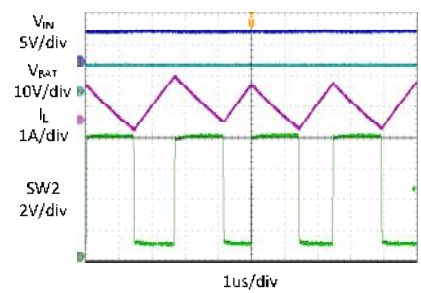

Tricklecharge @ 3 cells

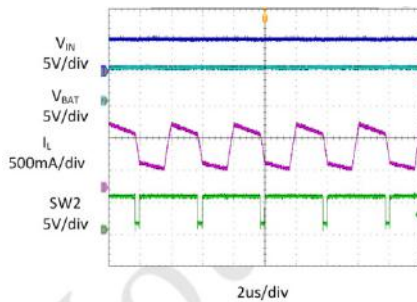

Constantcurrentcharge@ 3 cells

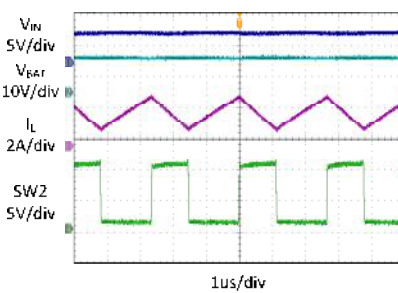

Constantvoltagecharge@ 3 cells

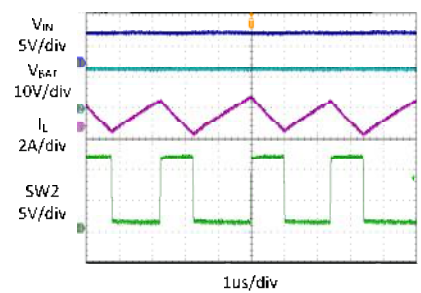



TYPICAL PERFORMANCE CHARACTERISTICS(Continued)

$V_{IN} = 5V$, $L = 3.3\mu H$, $C_{IN} = 20\mu F$, $C_{OUT} = 20\mu F$, $T_A = +25^\circ C$, unless otherwise noted

Charge efficiency @ 1 cell

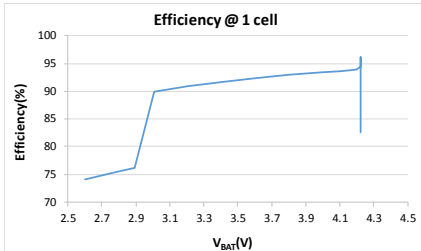

Charge efficiency @ 2 cells

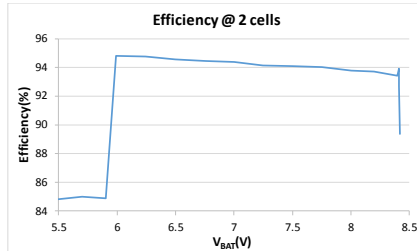

Charge efficiency @ 3 cells

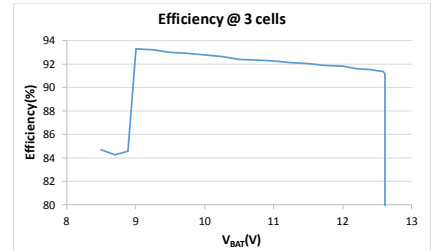

Charge current vs. VBAT @ 1 cell

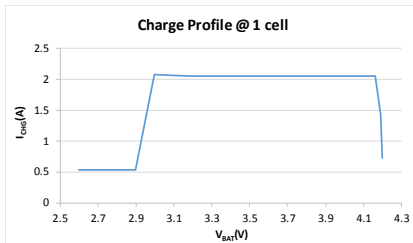

Charge current vs. VBAT @ 2 cells

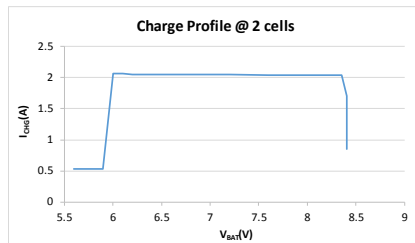

Charge current vs. VBAT @ 3 cells

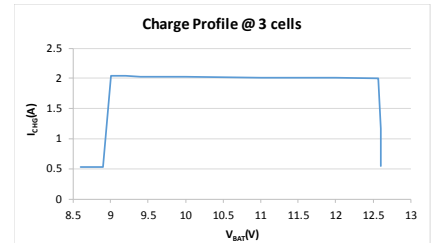



FUNCTIONAL DESCRIPTION

HX8808E is a monolithic buck-boost charger that can operate over a wide input voltage range of 4.2V to 17V. The full charge voltage and charge current can be programmable through external resistor. Low $R_{DS(ON)}$ N-channel power switches reduce the solution complexity and improve the efficiency.

The DC-DC converter utilizes proprietary single inductor current-mode control to guarantee smooth transition between buck and boost operation with better dynamic response and cycle-by-cycle current protection.

Compensation is done internally on the chip. The HX8808E operates in PFM mode at light load. In PFM mode, switching frequency is continuously controlled in proportion to the load current, i.e. switch frequency is decreased when load current drops to boost power efficiency at light load by reducing switching-loss, minimizing the circuit.

The HX8808E can operate in charge mode if a logic High is on CE pin. In charge mode, if the VIN voltage is lower than battery voltage, it is a boost converter. When the VIN voltage is higher than battery voltage, it is a buck converter.

Charge mode

In charge mode, HX8808E regulates the battery current according to input voltage and battery voltage. It charges battery with three phases: trickle charge, constant current charge, constant voltage charge and charge termination. Figure 1(a) is a typical charge profile. Figure 1(b) is a charge profile with input current limit. When the input current is limited, the system decreases the charge current.

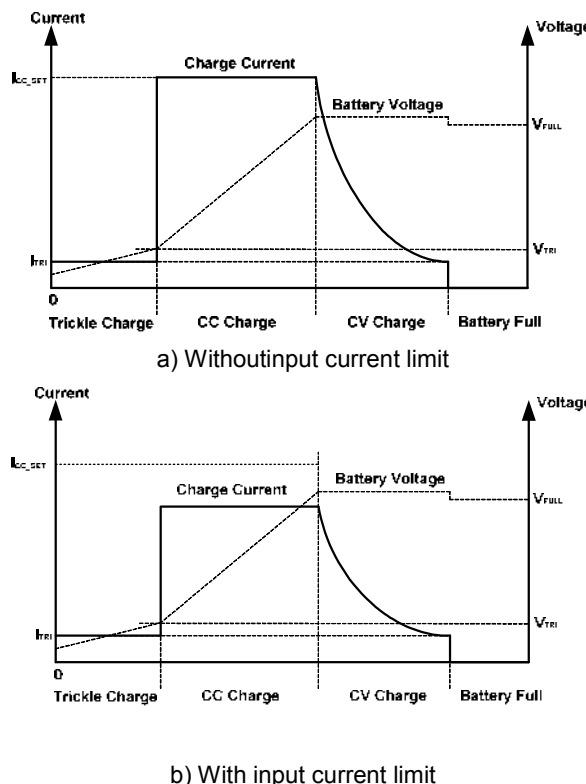

Figure 1 Typical Charge Profile

Trickle charge

The HX8808E charges the battery with I_{TRI} when battery voltage is less than V_{TRI} . If charging remains in TC mode beyond the trickle-charge time T_{TRI} , charging terminates.

CC charge

When the battery is higher than V_{TRI} , the device charges the battery with I_{CC} if the input current is sufficient. When input current limit is hit, the device reduces the charge current automatically. The HX8808E can set the charge current through R_{ISET1} and R_{ISET2} , we recommend R_{ISET1}/R_{ISET2} is around 4/3. The maximum charge current is up to 3A.

$$I_{CC}(A) = \frac{10(A)R_{ISET1}(k\Omega)}{R_{CS}(m\Omega)}$$

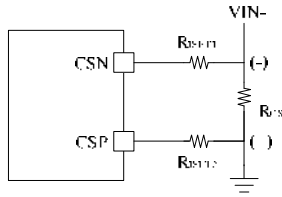

Figure 2 Typical Charge Profile

For 1A cc charge current, we recommend $R_{ISET1}=2k$, $R_{ISET2}=1.5k$, $R_{CS}=20m\Omega$; and for 2A cc charge current, we recommend $R_{ISET1}=2k$, $R_{ISET2}=1.5k$, $R_{CS}=10m\Omega$.

CV charge

When battery voltage equals to V_{CV} , the device regulates the battery voltage and reduces the charge current reduces automatically.

The customer can select 2 cells or program the V_{CV} through BATFB pin. Connect BATFB to GND selects 2 cells. The V_{CV} can also be programmable by resistor divider connected to BATFB, when the HX8808E detect a resistor connect to this pin. We recommend the 1% accuracy resistor should be used in order to achieve the accuracy of full charge voltage. The full charge voltage configuration shows in figure 3.

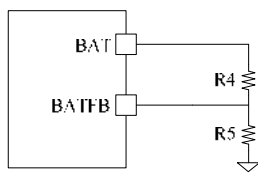

Figure 3 Full Charge Voltage Configure

$$V_{CV}(V) = \frac{1.2V \times (R_4 + R_5)}{R_5}$$

Charge termination

If the battery voltage is higher than V_{FULL} , and the charge current is less than charge termination current I_{TER} for T_{FULL} , the charge process terminates.

Auto recharge

Once the battery charge cycle completes, the charger remains off. A new charge cycle automatically begins when the battery voltage falls below the auto-recharge threshold V_{REC} if the input adaptor is present. The idle mode to charge mode transition also restarts the charge cycle.

Charging status indication

The HX8808E has open-drain output for charge status. Connect a current limit resistor and a LED from VCC to this pin can.

When charge is in progress, the STAT pin output LOW. When charge is completed or charger is in sleep mode, the STAT pin is output HIGH. When charge suspend at fault condition, the STAT pin blinks at 1Hz.

Dynamic input Current Tracking Scheme

HX8808E detects the VIN pin, if the VIN pin voltage is higher than V_{IN_UVP} rising threshold for 150ms, the HX8808E starts charging with a limited charging current. When the adaptor is over load, the DRP pin drops below the internal reference 0.9V, HX8808E will decrease the charging current. We recommend the ratio of $R1/R2$ is around 4.1. The input voltage sense shows in figure 4, choose $R1$, $R2$ to set the input voltage threshold.

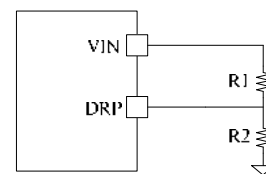

Figure 4 VIN Droop Voltage Configure

$$V_{IN_ALLOWANCE}(V) = \frac{V_{DRP}(V) \times (R_1 + R_2)}{R_2}$$

Thermal Control

When the junction temperature of the HX8808E



rises above 135°C, it begins to reduce the output power to prevent the temperature from rising further. If the junction temperature of the HX8808E rises above 150°C, the discharging process stops.

Shut-down Mode

The HX8808E shuts down when voltage at CE pin is below charge enable threshold. The entire regulator is off.

Battery temperature protection

For battery protection during charge mode, the device monitors the battery temperature through NTC pin. When the voltage of the NTC pin is outside the thresholds, the charge progress is suspended. In addition, STAT pin blinks at 1Hz to inform fault condition. Once temperature

returns within thresholds, the charge is recovered.

PCB Layout Note

For minimum noise problem and best operating performance, the PCB is preferred to following the guidelines as reference.

1. Place the input decoupling capacitor as close to HX8808E (VIN pin and PGND) as possible to eliminate noise at the input pin. The loop area formed by input capacitor and GND must be minimized.
2. Put the current sense resistor R_{CS} as close as possible to the current set resistors R_{ISET} for better current accuracy.
3. The ground plane on the PCB should be as large as possible for better heat dissipation



REFERENCE DESIGN

Reference 1: Single cell charge with input current limit

V_{IN} : 4.6V ~ 20V

V_{BAT} : 3V ~ 4.2V

I_{IN_LIM} : 2A

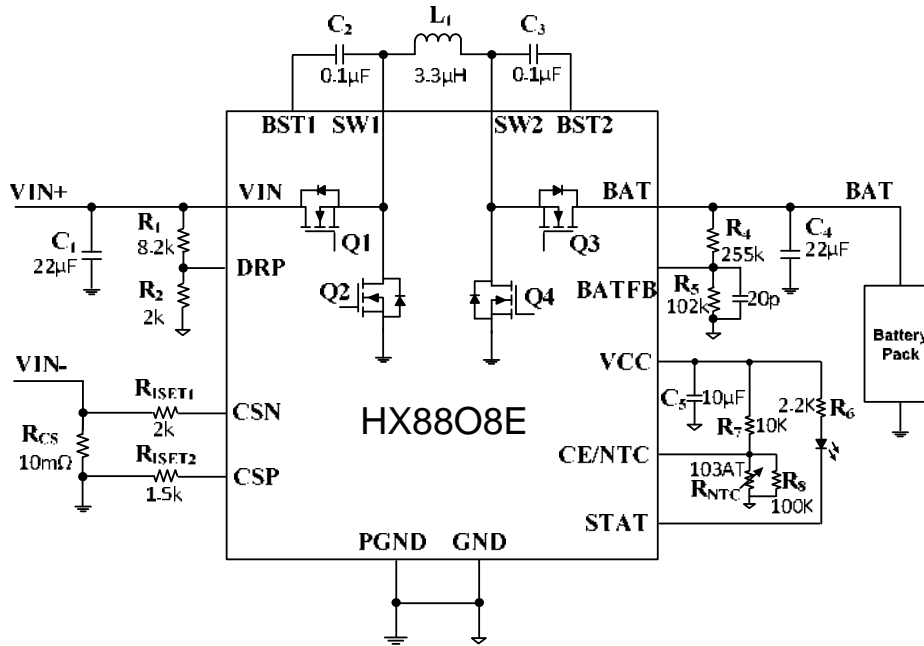

Reference 2: 2 cells charge with input current limit

V_{IN} : 4.6V ~ 20V

V_{BAT} : 6V ~ 8.4V

I_{IN_LIM} : 2A

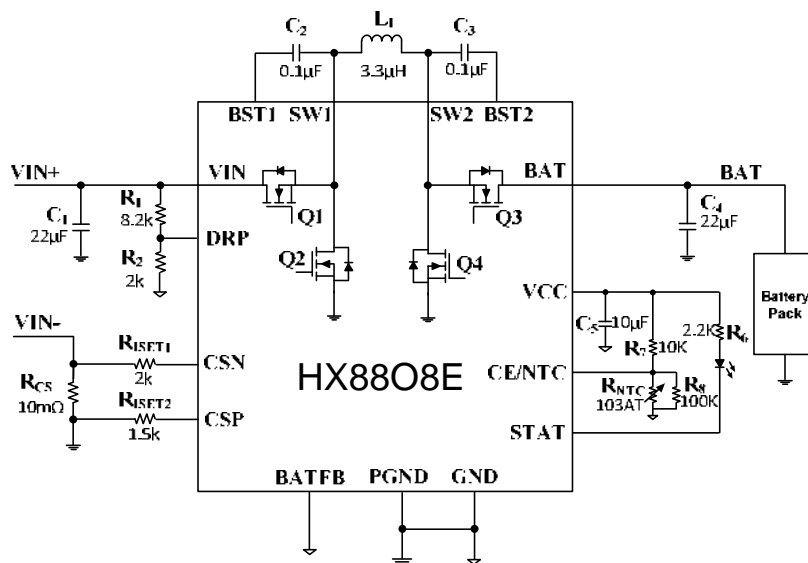



Reference 3: 3 cells charge with input current limit

V_{IN} : 4.6V ~ 20V

V_{BAT} : 9V ~ 12.6V

I_{IN_LIM} : 2A

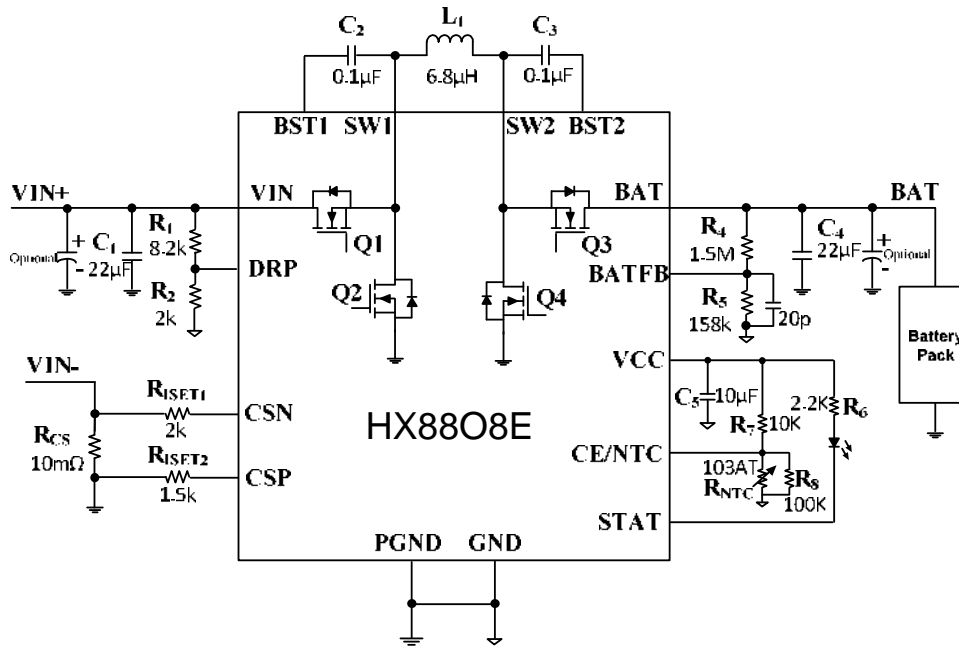

Reference 4: Single cell charge with battery current limit

V_{IN} : 4.6V ~ 20V

V_{BAT} : 3V ~ 4.2V

I_{BAT_LIM} : 2A

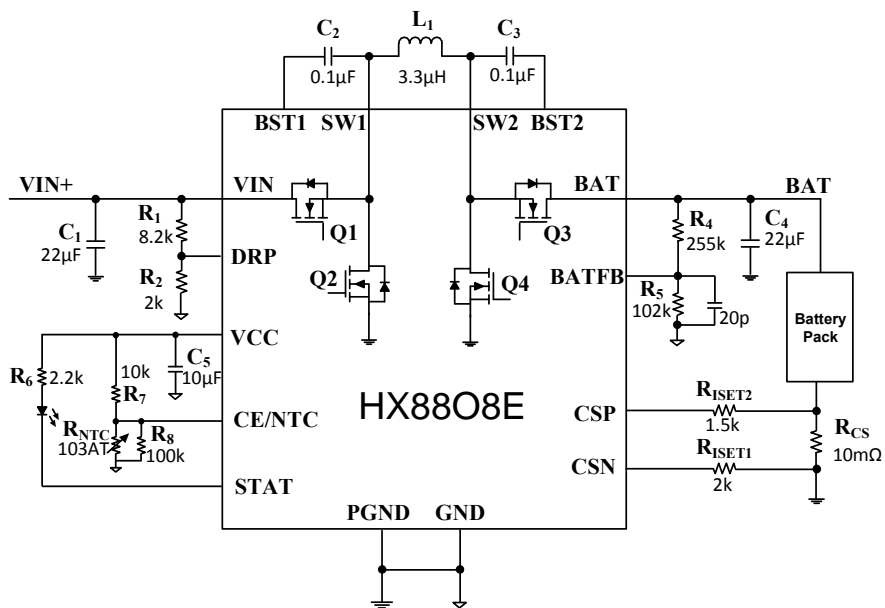



PACKAGE OUTLINE

